

MADE IN THE USA

Revelite AL
art light

The all-new Revelite AL is a revolutionary picture light that is custom built and tuned at our facility in Southern California. This fixture evenly illuminates the entire surface of a painting using an extremely high color-rendering light source. The uniformity and quality of light that this fixture emits is not achievable with the standard off-the-shelf fixtures available today. The technology in the Revelite AL does not emit dangerous amounts of UV or heat. All of these unprecedented attributes are embodied in an unobtrusive fixture profile that almost disappears when one views the art.

A revolutionary art light custom tailored to provide even and accurate illumination.

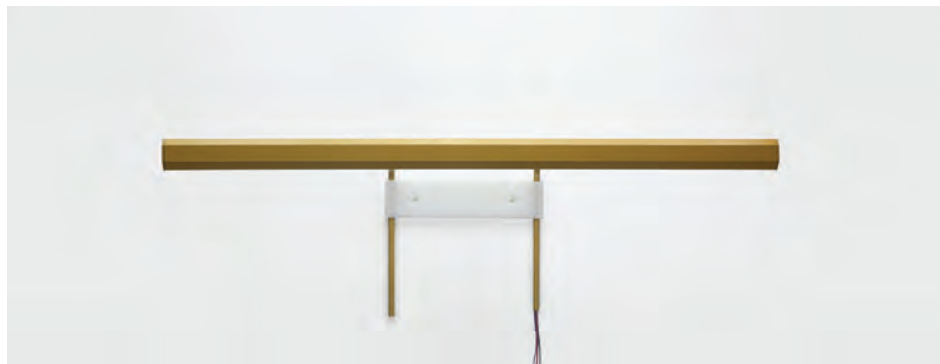

white



gold



oil rubbed bronze



black



brushed aluminum



In over 40 years of being in the art business I have never seen a better quality light to illuminate art work than the new Revelite. In my opinion Revelite will revolutionize the art lighting industry.

— George Stern,

 **illumination**

425 Peachtree Hills Ave. NE #3 Atlanta, GA 30305
404.876.1064 sales@illumco.com

"These lights revealed subtleties in paintings you just don't see with ordinary lights. I think we are seeing, truly for the first time, what the artist really wanted us to see." — Pat Trenton, Ph.D.
(nationally recognized art expert, curator and writer).



Typical Technology



Revelite Technology

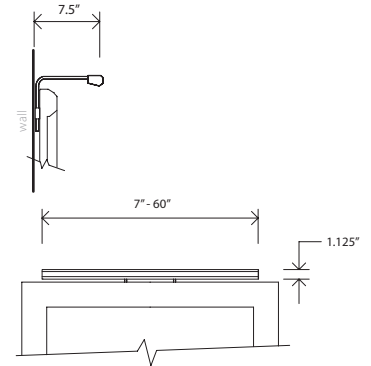

Dimensions - 7" to 60" x 7.5" x 1.125"

Two models: The Revelite AL1 is optimized for paintings up to 16 inches tall, and the Revelite AL2 is optimized for paintings from 16 to 36 inches tall. Both models are available in widths from 7 to 60 inches. If a piece is wider than 60 inches, multiple fixtures can be installed side by side.

Patent pending technology and optics that light the entire surface of the painting uniformly

High CRI LED's that render color as the artist intended color to be rendered
CRI=90+ R_v=85 (saturated reds)

No ultra violet light: safer for use with works on paper, oil painting, lithography, archival photography, and other ultra violet sensitive mediums

Fully dimmable with two zone dimming and individual light trajectory control

Inconspicuous small size: the hood is only 2.25 by 1.125 inches

Low power consumption and low heat

Long life: LED's are rated 50,000 hours

Minimal stray light: optics focus most light to the painting surface, not the wall

Standard finishes include brushed aluminum, gold, white, black, and oil rubbed bronze. Please inquire about custom finishes

Input Voltage: 24VDC
(adaptor included, hardwire and plug in versions available)

Max Power Consumption:
AL1 - 5W per foot
AL2 - 10W per foot

Max Light Output:
AL1 - 405 lumens per foot
AL2 - 810 lumens per foot

Color Temperature: 3000K

CRI: 90 min, 95 typical (R9=85+)

Dimming: included dimmer switch or 0-10V standard

