

Mos 01

Design / Diseño:
Joana Bover / 2008

Typology: Pendant lamp
Tipología: Suspensión

Environment: Indoor
Ambiente: Interior

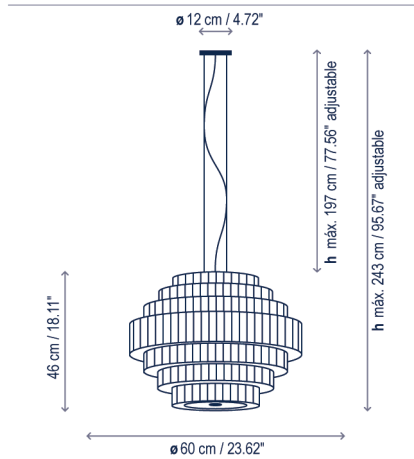

Technical description / Descripción técnica:

 Net Weight: 11.82 lbs
Peso Neto: 11.82 lbs

 1 Box/Caja
24.02 x 24.02 x 19.69 inches | 6.5703 ft³
Gross Weight / Peso bruto: 16.49 lbs

Materials: Iron
Materiales: Hierro

Lower diffuser: Optical glass
Difusor inferior: Cristal óptico

Transparent electrical cable. Stainless steel tensor cables.
Cable eléctrico transparente. Cables tensores de acero inoxidable.

Shade GWFI: 960°
Hilo incandescente pantalla: 960°

Customizable
Personalizable

Bulbs not included
Bombillas no incluidas

Certifications
Certificaciones   

Spare parts / Recambios:

R224DIF1 Diffuser / Difusor
R411301 Tensor 1,5 m / Tensor 1,5 m
R411303 Tensor 3 m / Tensor 3 m
R411305 Tensor 5 m / Tensor 5 m
R907004U Cable 3X18AWG / Cable 3X18AWG

Lamps description / Descripción lámpara:

 120V 60Hz | DRY | IP-20 |  3 x 60 W E26 A15 INC |  3 x 5 W E26 A15 LED

Ref	Finishing / Acabados	Ean13
224P617U	White Translucent Ribbon Shade Pantalla Cinta Translúcida Blanca	8436535532181
224P618U	Cream Translucent Ribbon Shade Pantalla Cinta Translúcida Crema	8436535532198
224P619U	Red Translucent Ribbon Shade Pantalla Cinta Translúcida Roja	8436535532204

bover
barcelona lights

1231 Collier Road,
Suite C
Atlanta, GA 30318
United States

T. +1 (404) 924 2342
info@boverusa.com
www.boverusa.com

Family / Familia: Mos

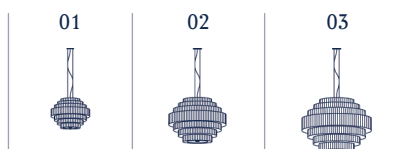



425 Peachtree Hills Ave. NE #3 Atlanta, GA 30305
404.876.1064 sales@illumco.com

Mos 02

Design / Diseño:
Joana Bover / 2008

Typology: Pendant lamp
Tipología: Suspensión

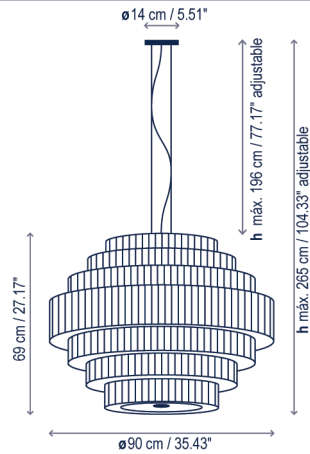
Environment: Indoor
Ambiente: Interior



Technical description / Descripción técnica:

 Net Weight: 26.5 lbs
Peso Neto: 26.5 lbs

 1 Box/Caja
41.73x38.19 x 29.53 inches | 27.233 ft³
Gross Weight / Peso bruto: 48.85 lbs

Materials: Iron
Materiales: Hierro

Lower diffuser: Optical glass
Difusor inferior: Cristal óptico

Transparent electrical cable. Stainless steel tensor cables.
Cable eléctrico transparente. Cables tensores de acero inoxidable.

Shade GWFI: 960°
Hilo incandescente pantalla: 960°

Customizable
Personalizable

Bulbs not included
Bombillas no incluidas

Certifications
Certificaciones   

Spare parts / Recambios:

R224DIF2 Diffuser / Difusor
R411301 Tensor 1,5 m / Tensor 1,5 m
R411303 Tensor 3 m / Tensor 3 m
R411305 Tensor 5 m / Tensor 5 m
R907004U Cable 3X18AWG / Cable 3X18AWG

Lamps description / Descripción lámpara:

 120V 60Hz | DRY | IP-20 |  5 x 60 W E26 A15 INC |  5 x 5 W E26 A15 LED | 

Ref	Finishing / Acabados	Ean13
224P622U	White Translucent Ribbon Shade Pantalla Cinta Translúcida Blanca	8436535532228
224P623U	Cream Translucent Ribbon Shade Pantalla Cinta Translúcida Crema	8436535532235
224P624U	Red Translucent Ribbon Shade Pantalla Cinta Translúcida Roja	8436535532242

bover
barcelona lights

1231 Collier Road,
Suite C
Atlanta, GA 30318
United States

T. +1 (404) 924 2342
info@boverusa.com
www.boverusa.com

Family / Familia: Mos

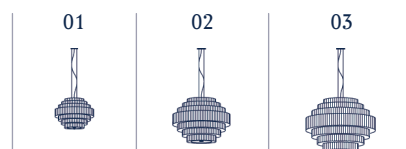



425 Peachtree Hills Ave. NE #3 Atlanta, GA 30305
404.876.1064 sales@illumco.com

Mos 03

Design / Diseño:
Joana Bover / 2008

Typology: Pendant lamp
Tipología: Suspensión

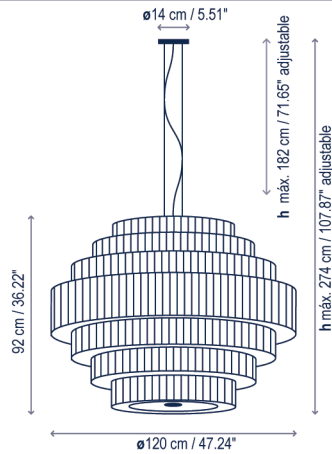
Environment: Indoor
Ambiente: Interior



Technical description / Descripción técnica:

lbs Net Weight: 37,52 lbs
Peso Neto: 37,52 lbs

Box/Caja
48.82 x 48.82 x 43.31 inches | 59.73 ft³
Gross Weight / Peso bruto: 57,92 lbs

Materials: Iron
Materiales: Hierro

Lower diffuser: Polycarbonate
Difusor inferior: Policarbonato

Transparent electrical cable. Stainless steel tensor cables.
Cable eléctrico transparente. Cables tensores de acero inoxidable.

Shade GWFI: 960°
Hilo incandescente pantalla: 960°

Customizable
Personalizable

Bulbs not included
Bombillas no incluidas

Certifications
Certificaciones

Spare parts / Recambios:

R224DIF3U Diffuser / Difusor
R411301 Tensor 1,5 m / Tensor 1,5 m
R411303 Tensor 3 m / Tensor 3 m
R411305 Tensor 5 m / Tensor 5 m
R907004U Cable 3X18AWG / Cable 3X18AWG

Lamps description / Descripción lámpara:

120V 60Hz | DRY | IP-20 | 6 x 60 W E26 A19 INC | 6 x 10 W E26 A19 LED |

Ref	Finishing / Acabados	Ean13
224P621U	White Translucent Ribbon Shade Pantalla Cinta Translúcida Blanca	8436535532211
224P625U	Cream Translucent Ribbon Shade Pantalla Cinta Translúcida Crema	8436535532259
224P626U	Red Translucent Ribbon Shade Pantalla Cinta Translúcida Roja	8436535532266

bover
barcelona lights

1231 Collier Road,
Suite C
Atlanta, GA 30318
United States

T. +1 (404) 924 2342
info@boverusa.com
www.boverusa.com

Family / Familia: Mos

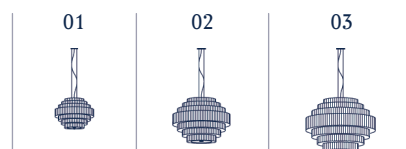

illuminaTIONS
425 Peachtree Hills Ave. NE #3 Atlanta, GA 30305
404.876.1064 sales@illumco.com