

PLOT SP

TECHNICAL DATA:

CERTIFICATIONS:



1x12,5w 120V/60HZ LED

VOLUME Mc 0,28
GROSS WEIGHT Kg 15
NET WEIGHT Kg 9

download

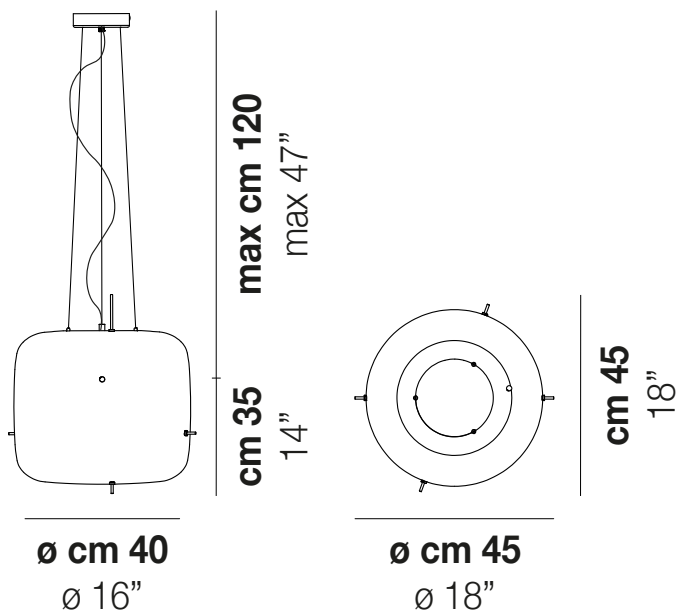

SHADE FINISHING



CR/NE

CR/OT

FU/NE

FU/OT

FRAME FINISHING



NEO