



TITANIA

design Alberto Meda / Paolo Rizzatto, 1989

**LUCE
PLAN**

Type:	Suspension
Light source:	205W HSGST E27 energy saver EEL: D LED E27 - Ø max 38mm - L 150mm EEL: A++/A+/A
Product use:	Indoor
Materials:	Steel bearing structure, aluminium lamellar shell
Colors:	Natural aluminium structure Filters in violet, yellow, green, blue, red
Description:	Light and versatile, the use of a pair of polycarbonate filters allows this lamp to change colour without interfering with the emission of white light. The complex aluminium rib assembly solution reflects light through a transparent and surprising shape. A spherical counterweight allows the lamp to be adjusted in height.
Insulation class:	  
Awards:	Concours de la Création Artistique SIL/Paris 1990 Special mention Compasso d'Oro ADI Milano 1991, selection Design Plus Ambiente, Frankfurt 1992, special prize
Reference code:	D17 1D1700000020 alu

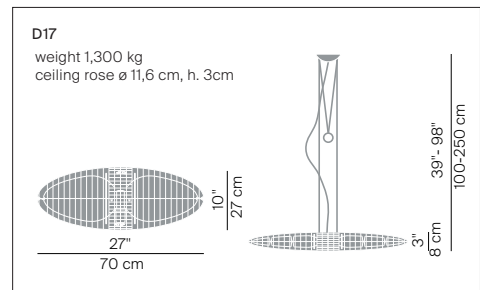

www.luceplan.com

 **illuminations**
425 Peachtree Hills Ave. NE #3 Atlanta, GA 30305
404.876.1064 sales@illumco.com

QUEEN TITANIA

design Alberto Meda / Paolo Rizzato, 2005



Type: Suspension

Light source: max 2 x 205W HSGST E27 energy saver EEL: D
 2 x 105/140W HSGSA E27 energy saver EEL: D
 2 x LED 13W E27 EEL: A

Product use: Indoor

Materials: Steel bearing structure, aluminium lamellar shell

Colors: Structure in alu
 Filters in violet, yellow, green, blue, red

Description: With its doubled size and scale, it is designed to enlighten large spaces. A pair of interchangeable filters colour the body of the fitting, without interfering with the emission of white light.

Insulation class:

Reference code: Structure D17 Q 1D170QHAL020

Filters
 1D170Q/01006 yellow
 1D170Q/01009 violet
 1D170Q/01010 blue
 1D170Q/01007 red
 1D170Q/01011 green

Accessories
 D17Q/02 1D170Q/02020 alu

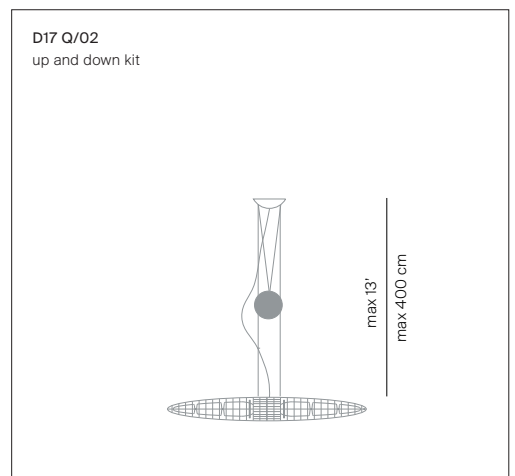
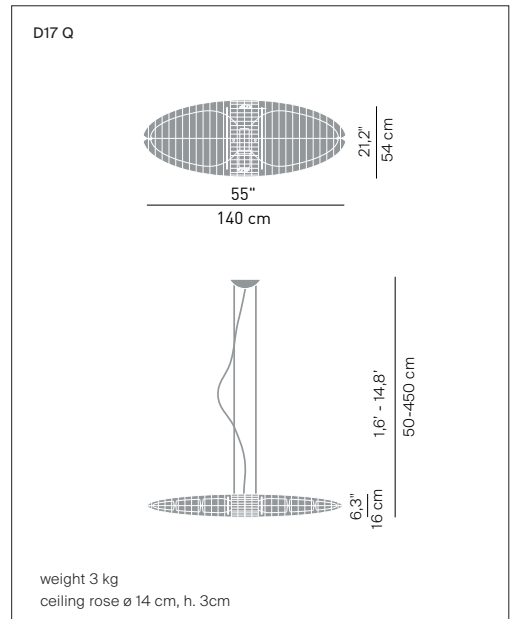

illuminations
 425 Peachtree Hills Ave. NE #3 Atlanta, GA 30305
 404.876.1064 sales@illumco.com