

## HO.001

**Typology:** Wall lamp

### Description / Descripción

- Lacquered white metal suport.
  - Natural wood hoops
  - LED lighting system.
  - TRIAC dimmable LED
- *Base metálica lacada en blanco.*
  - *Aros de madera natural.*
  - *Sistema de iluminación LED.*
  - *Regulable por TRIAC*

### General measures / Medidas generales

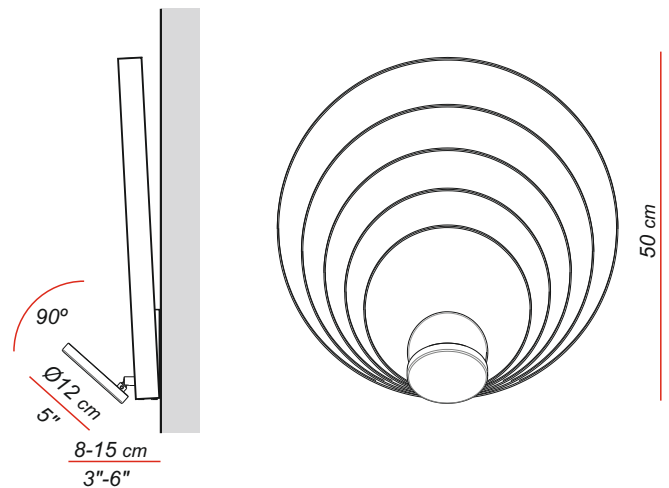

### Electrical characteristics Características eléctricas

Voltage: 220-230V / 50-60Hz  
120V / 60Hz (USA)

#### European version

HO.001



LED 10W · 230V  
900lm · 2700K  
TRIAC dimming

#### USA version

TUS.HO.001

LED 10W · 120V  
900lm · 2700K  
TRIAC dimming

### Packaging Embalaje

1 box

55x55x10 cm / 0,03 m<sup>3</sup>  
22"x22"x4" / 1 ft<sup>3</sup>

Peso neto: 2 Kg  
Net weight: 4,4 lb

### Materials and finish Materiales y acabados

Support  
Soporte

**White lacquered metal**  
Metálico lacado blanco

Lampshade  
Pantalla

**Natural wood**  
Madera natural

#### Certifications:

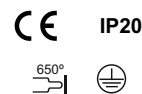

#### USA Certifications:

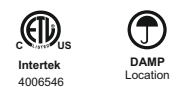

Led module included / Módulo LED incluido



Light for indoor use only / Luminaria solo para uso interior