

Indoor & Outdoor

BM.T024E.14 / BM.T124E.14

Typology: Suspension / Suspensión

Description / Descripción

- Table lamp with metal structure treated for outdoors.
- Braided with double acrylic cord suitable for outdoor use with UV treatment.
- Available in several colors.
- *Indoor and outdoor (IP65) versions.*
- *Luminaria de mesa con estructura metálica tratada para exteriores.*
- *Trenzada con doble cordón acrílico apto para el exterior con tratamiento UV.*
- *Disponible en varios colores.*
- *Florón metálico lacado negro.*
- *Versión para interior y exterior (IP65)*

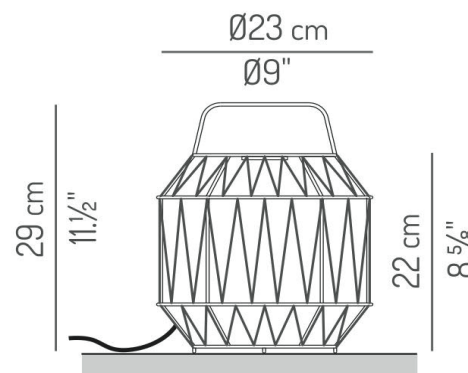

Light Source / Fuente de luz

220-230V / 50-60Hz
120V / 60Hz (USA)

European version

BM.T024E.14
indoor



LED 10W 230V 2700K 880lm
Dimmable TRIAC



BM.T124E.14
outdoor



LED 10W 230V 2700K 880lm
Dimmable TRIAC



USA version

TUS.BM.T024E.14
indoor



LED 10W 120V 2700K 880lm
Dimmable TRIAC

TUS.BM.T124E.14
outdoor



LED 10W 120V 2700K 880lm
Dimmable TRIAC

LED module included / módulo LED incluido

Packaging / Embalaje

1 box

29x29x27 cm / 0,03 m³
12"x12"x11" / 1 ft³

Peso neto: 1 Kg
Net weight: 2,2 lb

Materials & Finishings / Materiales y acabados

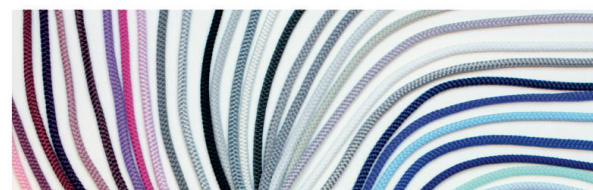

Lampshade with double braided cord

For available colors check general catalogue



Black lacquered structure

Estructura lacada en negro.

Indoor:

Black hand switch / Interruptor de mano negro

Outdoor:

Without switch / Sin interruptor

Certifications:



IP20
(indoor)

IP65
(outdoor)

USA Certifications:



(indoor)

(outdoor)

(PENDING)

Suitable for outdoor use / Apta para uso exterior

BM.T124.14 / TUS.BM.T124.14

Description / Descripción

- Portable table lamp.
 - Lamp without cables. Rechargeable LED lighting system
 - Polypropylene cord lampshade with UV-treated in different colors.
 - Luminaire suitable for outdoor use. IP66
- *Modelo de sobremesa portátil.*
 - *Luminaria sin cables. Fuente de luz LED recargable.*
 - *Pantalla de cordón polipropileno trenzado, disponible en varios colores. Tratamiento UVA.*
 - *Apto para exteriores. IP66.*

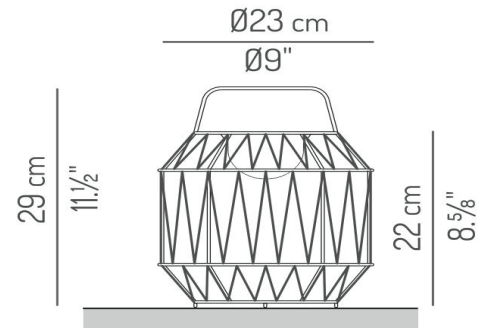

Rechargeable LED / LED recargable

- ▶ LED 3W / 2700K / 290lm
- ▶ Battery autonomy: 7h (at peak performance)
- ▶ LED dimmer: 10% / 50% / 100%
- ▶ Remote control.
- ▶ Switch (ON/OFF) on the LED module.
- ▶ Induction charging system. 800mA.
- ▶ Battery charging time: 4h
- ▶ Led module suitable for outdoor use. **IP66**

- ▶ *LED 3W / 2700K / 290lm*
- ▶ *Autonomía de 7h (funcionando al 100%)*
- ▶ *3 intensidades del luz: 10% / 50% / 100%*
- ▶ *Sistema de control por mando a distancia*
- ▶ *Interrupor táctil ON/OFF en la base del módulo*
- ▶ *Sistema de carga por inducción 800mA*
- ▶ *Tiempo de carga: 4h*
- ▶ *Apto para exterior: IP66*

Packaging / Embalaje

1 box

32x32x25 cm / 0,03m³
12"x12"x 10" / 1ft³

Peso neto: 1 Kg
Net weight: 2,5 lb

Features / Características



Lampshade with double braided cord

For available colors check general catalogue

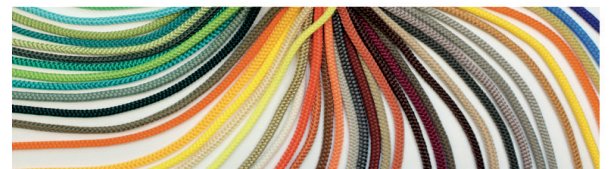

Certifications:



USA Certifications:



Suitable for outdoor use / Apto para uso exterior

